



## INFLUENCE OF THE SEMI-RIGID BOLTED STEEL JOINTS ON THE FRAME BEHAVIOUR

Alfonsas Daniūnas<sup>1</sup>, Kęstutis Urbonas<sup>2</sup>

*Dept of Steel and Timber Structures, Vilnius Gediminas Technical University,  
Saulėtekio al. 11, LT-10223 Vilnius, Lithuania*

*E-mail: <sup>1</sup>alfonsas.daniuнас@vgtu.lt; <sup>2</sup>kestutis.urbonas@vgtu.lt*

*Received 27 Oct. 2009; accepted 27 Jan. 2010*

**Abstract.** This research work describes the analysis of steel semi rigid joints that are subjected to bending and tension or compression. The main attention is focussed on the beam-to-beam and plate bolted joints. Usually influence of axial force is neglected. In fact, the level of tension or compression of axial force can be significant and has some impact on joint behaviour and on its stiffness and strength characteristics. Nowadays the most powerful method for the estimation of joints characteristics is the component method. The adaptation of the component method for the determination of joints characteristics under bending and axial forces is shown in the paper. Some numerical results of calculations of steel frameworks are presented in this paper as well (Daniūnas and Urbonas 2008).

**Keywords:** steel structures, semi-rigid joints, moment-rotation curve, rotational stiffness, moment resistance, frame behaviour.

### 1. Introduction

The semi-rigid joint behaviour under bending is described by moment-rotation curve (Bahaari and Sherbourne 2000; Chen *et al.* 1996; Wilkinson and Hancock 2000; Sokol *et al.* 2002; Eurocode 3). Joints are also influenced by axial and shear forces. The tension and compression axial forces and shear forces also have influence on joint behaviour. The review of the generalised component-based model for semi-rigid beam-to-column connections including axial force versus bending moment is presented in (Del Savio *et al.* 2009).

The empirical, analytical, numerical, mechanical methods and experimental tests are applied for compose of moment-rotation  $M-\Phi$  curve (Faella *et al.* 2000; Mohamadi-Shooreh and Mofid 2006). For practical needs the so-called mechanical component method is the most attractive method. Originally, the component method was developed only for estimation of bending moment response. It allows to obtain the joint rotational stiffness and moment resistance regarding mechanical properties and geometrical data of the joint (Jaspart *et al.* 2001; Daniūnas *et al.* 2006; Juozapaitis *et al.* 2008; Kala *et al.* 2009). Investigations show that the structure of the component method allows to apply this method to the cases where joint is acting by more complicated forces combination such as the interaction of bending moment and tension or compression axial force.

The iterative procedure is suggested for the analysis of steel structures evaluating flexibility of joints is suggested in this article. The every new iteration of structure calculation is performed adopting stiffness and strength

joint characteristics obtained that were obtained in the previous iteration.

### 2. Modelling of component method for steel joints

The steel joints are treated by axial forces, shear forces and bending moments (Cerfontaine and Jaspart 2002; de Lima *et al.* 2002). The influence of these forces on the joint's characteristics strongly depends on the joint's type. Interaction influence of simultaneously acting bending moment and axial force on joint behaviour could be important for end-plate knee joints (Fig. 1) and could notably influence characteristics of these joint.

The investigation results in the procedure, which evaluates the behaviour of steel joints under the simultaneous action of bending moment and axial force. For that in the article is presented extension of the component method. According to the main idea, the characteristics of joint have to be calculated by the characteristics of the components of the joint. The component method allows one to characterize each component of the joint only by mechanical data and geometry of the joint.

The main idea of the component method relates to the characterization of the force-deformation relationship for each component of the joint.

For joints that are under the simultaneous action of bending moment and axial force, the procedures for the calculation of component's characteristics are the same as in making calculations of the joint's characteristics when influence of axial force is disregarded and only the bending moment is taken into account. A difference prevails when acting axial force increases or decreases

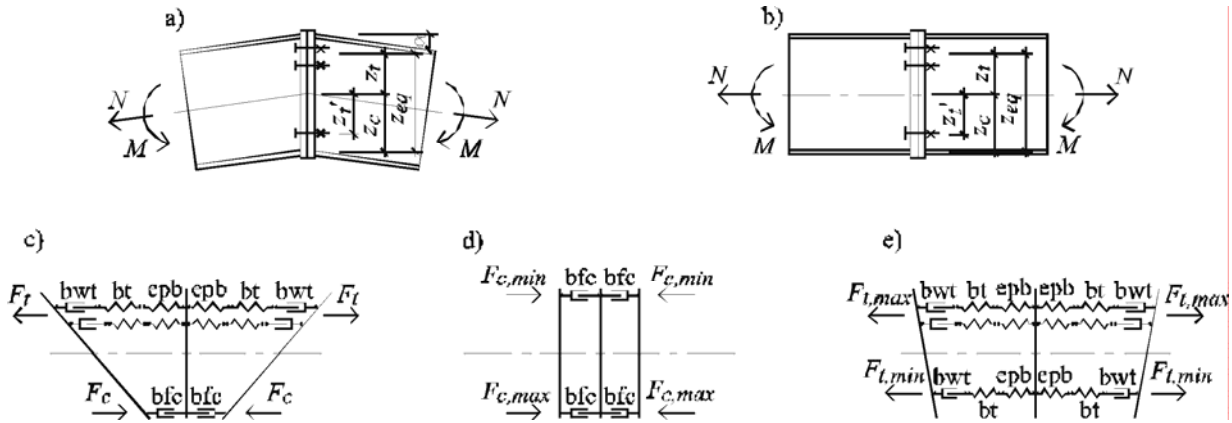

**Fig. 1.** Mechanical models and loading schemes of joint: a) beam-to-beam knee joint; b) beam-to-beam joint; c) lower part of joint in compression and upper part in tension forces; d) both sides of joint under compression forces; e) both sides of joint under tensile forces

the force in components from the bending moment (Daniūnas and Urbonas 2007). Mechanical model of the joint depends on the values and directions of acting forces. Depending on the type of loading the parts of the joint can be under tension and under compression (Fig. 1, c), only under compression (Fig. 1, d) or only under tension (Fig. 1, e).

The rotation depends on the deformation of all the components  $i$  being under tension:

$$\Phi = \frac{\Delta_{t,eq}}{z_{eq}} \quad (1)$$

The initial stiffness of the joint can be found by the formula:

$$S_{j,ini} = \frac{M}{\Phi} = \frac{M \cdot z_{eq}}{\Delta_{t,eq}} \quad (2)$$

When both sides of the joint are under compression forces, then the joint behaves as ideally rigid.

The initial stiffness of the joint for case, when both sides of the joint are under tensile forces (Fig. 1, e) can be expressed as follows:

$$S_{j,ini} = \frac{M}{\Phi} = \frac{M(z_t + z_t')}{\Delta_{t,max,eq} - \sum \Delta_{t,min,i}} \quad (3)$$

The presented stiffness calculation formulas are applicable only in the case, when physical non-linearity does not occur. For the derivations of the formulas please see the reference (Daniūnas and Urbonas 2008).

The moment resistance of the joint under simultaneous action of axial forces and bending moments can be expressed as a function of axial force and resistance of the components. When one part of the joint is under tension and the other is under compression (Fig. 1, c), the moment resistance can be found by the formula:

$$M_{j,Rd} = \min \left\{ \begin{array}{l} \sum (F_{t,r,Rd} \cdot h_r) - N \cdot \cos \alpha \cdot z_c \\ F_{c,i,Rd} \cdot z_{eq} + N \cdot \cos \alpha \cdot z_t \end{array} \right\} \quad (4)$$

When both sides of the joint are under compression forces (Fig. 1, d), the moment resistance can be found by the formula:

$$M_{j,Rd} = z_c (2F_{c,max,i,Rd} + N \cdot \cos \alpha) \quad (5)$$

When both sides of the joint are in tension forces (Fig. 1, e), the moment resistance can be found by the formula:

$$M_{j,Rd} = \min \left\{ \begin{array}{l} \sum (F_{t,max,r,Rd} (h_r - z_c + z_t')) - N \cdot \cos \alpha \cdot z_t' \\ N \cdot \cos \alpha \cdot z_t - F_{t,min,i,Rd} (z_t + z_t') \end{array} \right\} \quad (6)$$

The above formulas could be used when the upper part of connection has two or more rows of bolts. In case the upper part of connection has only one row of bolts, the formulas are the same, whereas  $z_t$  is the distance between the centres of cross section to the upper bolt row.

There are only axial force and bending moment considered in this section. In case of significant shear force  $V$  in knee joints, the value  $(N \cdot \cos \alpha)$  should be changed into  $(N \cdot \cos \alpha \pm V \sin \alpha)$ . Where '+' or '-' depend on the direction of shear force.

The authors suggested the procedure for calculation of steel frames with semi-rigid joints that can be used as a part of designing iterative process of steel frames. The calculation of steel frames can be performed with software commonly used in design, which allows to evaluate rotational stiffness of the joints.

When the influence of axial force is taken into consideration, the calculations have to be performed by iterative approach until the changes of forces in structure between two iterations are neglected (Fig. 2).

### 3. Numerical examples of calculations of joints

This chapter presents the importance of influence of axial force to the behaviour of steel knee joints.

The behaviour of beam-to-beam knee joints is displayed in Fig. 3. Beams are connected through the end-plates by bolts. There are two bolt rows in the upper part of the joints. The beams are loaded by bending moments and axial forces. There is presented behaviour only of the

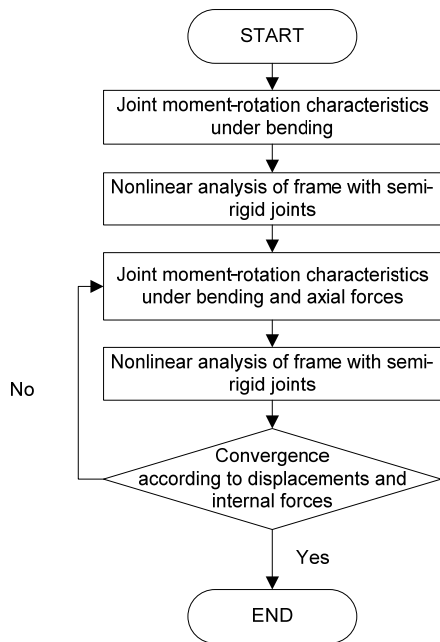

Fig. 2. Flowchart of frame analysis with semi-rigid joints under simultaneous action of bending moment and axial force

joint A30 as its behaviour is very typical of all the joints presented in Fig. 3. More detailed results of behaviour of other joints are presented in literature (Urbonas and Daniūnas 2005). Joint A30 is analysed when it is under bending moment and a different level of the axial force. Axial force is applied to cause compression or tension.

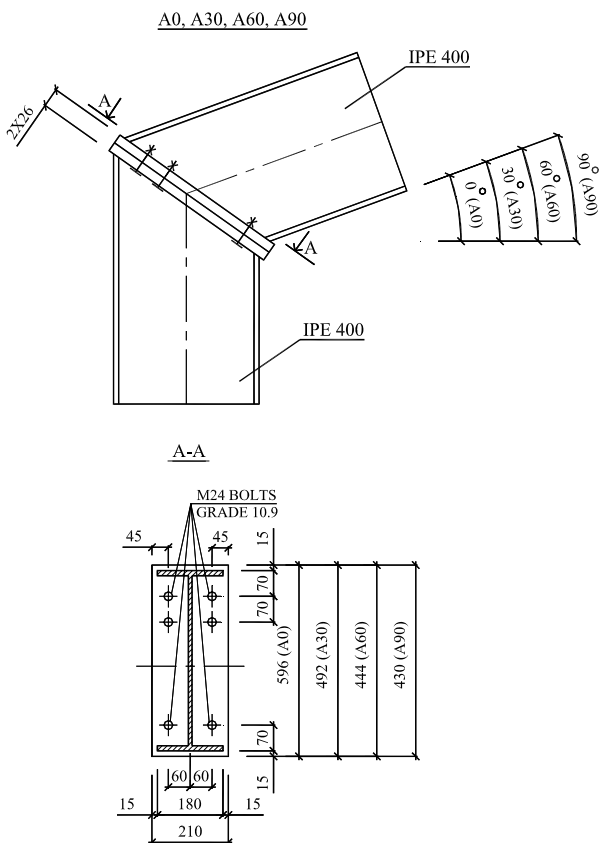

Fig. 3. Beam-to-beam knee joints (in mm): general view; section A-A

In Fig. 7 are presented stiffness calculation results of joint A30, when it is under different levels of the axial force. Compression or tension axial forces are applied to the joint and their values are equal to 10% and 25% of their ultimate value equal to axial load-bearing capacity of a joint.

As it is seen from comparison with results, the joint A30 loaded by bending moment and compressive axial force are more rigid than in case when it is loaded only by bending moment. The joint loaded by bending moment and tension axial force is less rigid than in case when it is loaded only by bending moment. Consequently, depending on the value and direction of the axial force the rigidity of the joint can change significantly.

$N$  in Fig. 4 means the axial force, index  $t$  indicates tension, and index  $c$  – compression.

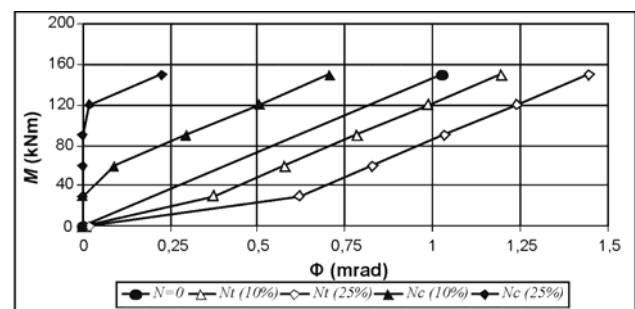

Fig. 4. Moment-rotation  $M-\Phi-N$  curves of joint A30 for different level of axial force

The decrease in rigidity of joint A30 is respectively about 30% and 80% is found in bending moment and tensile axial force that make 10% and 25% of ultimate tensile force, while the increase of joint rigidity is respectively about 15% and 30% affected by the interaction of bending moment and compressive axial force that is equal of 10% and 25% respectively of the ultimate compression force.

When the joint is loaded by tension axial force and relatively small bending moment the stiffness is less than the joint is loaded by the same axial force and by bending moment of large magnitude and for the joint loaded by the compressive axial force it will be vice versa.

#### 4. Numerical Examples of calculations of steel structures

To show the effect of semi-rigid joints on the behaviour of whole framed structures, the analysis of behaviour of a portal frame (Daniūnas and Urbonas 2008) and roofing structure (Urbonas and Daniūnas 2006) are presented. The joint characteristics under simultaneous action of bending and axial forces are obtained and analysis of framed structures is performed according to the above mentioned methods.

**Example 1.** Fig. 5 presents the structure loaded by uniformly distributed vertical and horizontal loads. Beams to the beams and beams to the columns of the portal frame are connected by the bolted end-plate knee joint (Fig. 5; joints „A” and „B”). The portal frame was investigated for the four cases of angle  $\alpha$  (0, 15, 30 and 45 degrees) and for the cases of end plates of thickness

with 12, 16, 20 and 26 mm. The calculations were performed for the joints characteristics taking into account the influence of simultaneous action of bending moment and axial force ( $M+N$ ) or only the influence of the bending moment ( $M$ ).

Presented results (Fig. 6 and 7) show the significant influence of axial forces on joints characteristics and frame displacements.

**Example 2.** In Fig. 8 is presented investigated roofing structure. Beams are connected by the bolted endplate knee joint „A”. Beams are simply supported and loaded by a uniformly distributed vertical load. Behaviour of the structure was investigated for the cases of end plates of 12, 16, 20 and 26 mm thickness. The characteristics of

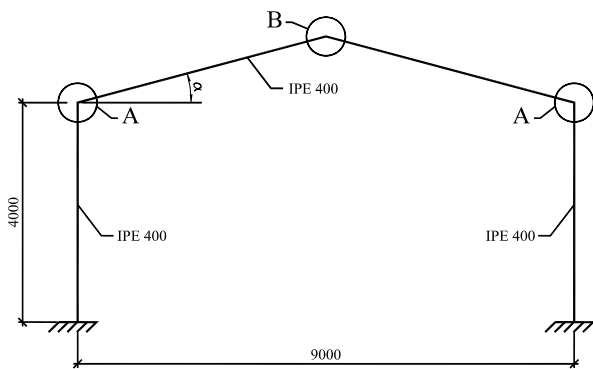

Fig. 5. Portal frame

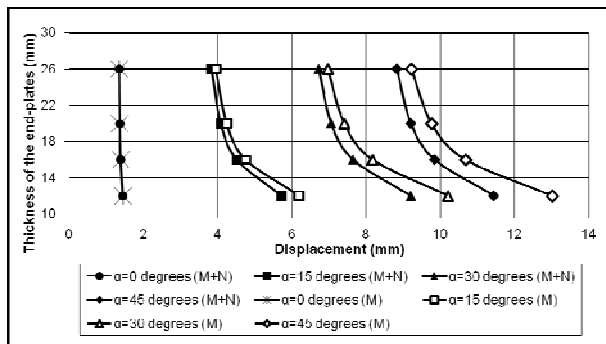

Fig. 6. Horizontal displacement of the top of the left column when the influence of axial forces is evaluated ( $M+N$ ) and disregarded ( $M$ )

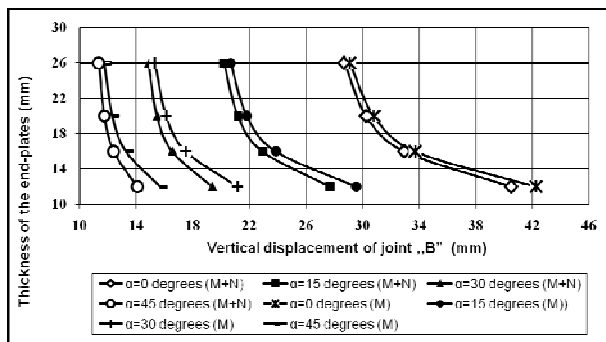

Fig. 7. Deflection of top joint „B” when the influence of axial forces is evaluated ( $M+N$ ) and disregarded ( $M$ )

the joint „A” were calculated taking into account the influence of simultaneous action of bending moment and axial force or only the influence of the bending moment. Analyzed example shows situation when tensile axial force decreases the rigidity of the joint „A” and changes the behavioural results of the whole investigated structure.

Results presented in Table 1 have shown the relevant influence of the axial force on the behaviour of the structure. Also, internal forces and displacements of the structure are strongly influenced by the thickness of the end-plates of the beam-to-beam joint.

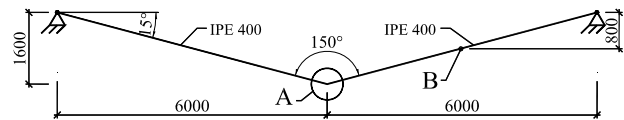

Fig. 8. Roofing structure

Table 1. Bending moment  $M$  (kNm), axial force  $N$  (kN) and deflection  $u_v$  (mm) of joint ‘A’ and point ‘B’ for 26, 20, 16 and 12 mm of thickness of end-plates in joint ‘A’

	Thickness of the end-plate (mm)							
	26		20		16		12	
	‘A’	‘B’	‘A’	‘B’	‘A’	‘B’	‘A’	‘B’
The influence of the axial force is estimated								
$M$	117.9	111.8	109.7	115.9	97.0	122.3	70.1	135.7
$N$	483.7	513.0	478.7	508.0	471.0	500.4	454.8	484.1
$u_v$	6.97	12.07	6.90	12.44	6.80	12.99	6.58	14.17
The influence of the axial force is disregarded								
$M$	127.9	106.8	122.8	109.3	115.0	113.3	97.4	122.1
$N$	490.0	519.0	486.6	516.0	482.0	511.2	471.3	500.6
$u_v$	7.05	11.64	7.01	11.86	6.94	12.21	6.80	12.98

From the presented results of calculation of steel structures in examples 1 and 2 it is evident that estimation of the simultaneous action of bending moment and axial force has a significant influence on the prediction of the behaviour of steel knee joint and whole steel frameworks.

### 5. Conclusion

The suggested application of the component method to the more complicated internal forces action such as interaction of bending moment and axial force allow more accurately obtain the joint stiffness and strength characteristics. Comparative analysis of steel structures when interaction of joints bending moment and axial force have been evaluated obtaining joints characteristic, the calculation results of internal forces and displacements differ when there is only bending moment of joints evaluated. In the issue, the characteristics of beam-to-beam joints with weighty axial forces have to be obtained with the interaction of bending moment and axial force.

### References

Bahaari, M. R.; Sherbourne, A. N. 2000. Behavior of eight-bolt capacity endplate connections, *Computers and Structures* 77: 315–25. doi:10.1016/S0045-7949(99)00218-7

- Cerfontaine, F.; Jaspert, J. P. 2002. Analytical study of the interaction between bending and axial force in bolted joints, *Eurosteel*, Coimbra, 997–1006.
- Chen, W. F.; Goto, Y.; Liew, J. Y. R. 1996. *Stability design of semi-rigid frames*. John Wiley & Sons.
- Daniūnas, A.; Kvedaras, A. K.; Sapalas, A.; Šaučiuvėnas, G. 2006. Design basis of Lithuanian steel and aluminium structure codes and their relations to Eurocode, *Journal of Constructional Steel Research* 62(12): 1250–1256. doi:10.1016/j.jcsr.2006.04.018
- Daniūnas, A.; Urbonas, K. 2008. Analysis of the steel frames with the semi-rigid beam-to-beam and beam-to-column knee joints under bending and axial forces, *Engineering Structures* 30(11): 3114–3118. doi:10.1016/j.engstruct.2008.04.027
- Daniūnas, A.; Urbonas, K. 2007. Characteristics of the semi-rigid bolted steel joints under bending and axial forces and its influence on the frame behaviour, in *Proceedings of the 9th International Conference “Modern Building Materials, Structures and Techniques”*. Selected papers. Vilnius: Technika, 512–516.
- Del Savio, A. A.; Nethercot, D. A.; Vellasco, P. C. G. S.; Andrade, S. A. L.; Martha, L. F. 2009. Generalised component-based model for beam-to-column connections including axial versus moment interaction, *Journal of Constructional Steel Research* 65(8–9): 1876–1895. doi:10.1016/j.jcsr.2009.02.011
- de Lima, L. R. O.; da Silva, L. S.; da S Vellasco, P. C. G.; de Andrade, S. A. L. 2002. Experimental analysis of extended end-plate beam-to-column joints under bending and axial force, *Eurosteel*, Coimbra, 1121–1130.
- Eurocode 3, EN 1993-1-8. 2005. Design of steel structures - Part 1-8: Design of joints, CEN Brussels, Belgium.
- Faella, C.; Piluso, V.; Rizzano, G. 2000. *Structural steel semi-rigid connections: theory, design and software*. Boca Raton: CRC Press LLC.
- Jaspert, J. P.; Weynand, K. 2001. Extension of the component method to joints in tubular construction, in *Proceedings of the Ninth International Symposium and Euroconference on tubular structures*. Düsseldorf, 517–523.
- Juozapaitis, A.; Kutas, R.; Jatulis, D. 2008. Mast behaviour analysis and peculiarities of numerical modelling, *Journal of Civil Engineering and Management* 14(1): 61–66. doi:10.3846/1392-3730.2008.14.61-66
- Kala, Z.; Melcher, J.; Puklický, L. 2009. Material and geometrical characteristics of structural steels based on statistical analysis of metallurgical products, *Journal of Civil Engineering and Management* 15(3): 299–307. doi:10.3846/1392-3730.2009.15.299-307
- Mohamadi-Shooreh, M. R.; Mofid, M. 2006. Parametric analyses on the initial stiffness of flush end-plate splice connections using FEM, *Journal of Constructional Steel Research* 64(10): 1129–1141. doi:10.1016/j.jcsr.2007.09.010
- Sokol, Z.; Wald, F.; Delabre, V.; Muzeau, J. P.; Švarc, M. 2002. Design of end plate joints subject to moment and normal force, *Eurosteel*, Coimbra, 1219–28.
- Urbonas, K.; Daniūnas, A. 2006. Behaviour of semi-rigid beam-to-beam joints under bending and axial force, *Journal of Constructional Steel Research* 62(12): 1244–1249. doi:10.1016/j.jcsr.2006.04.024
- Urbonas, K.; Daniūnas, A. 2005. Component method extension to steel beam-to-beam and beam-to-column knee joints under bending and axial forces, *Journal of Civil Engineering and Management* 11(3): 217–224.
- Urbonas, K.; Daniūnas, A. 2005. Semi-rigid steel joints under bending and axial force, in *Theoretical Foundations of Civil Engineering – XIII. Polish–Ukrainian International Conference*, 291–298.
- Wilkinson, T.; Hancock, G. J. 2000. Tests to examine plastic behaviour of knee joints in cold-formed RHS, *Journal of Structural Engineering* 126(3): 297–305. doi:10.1061/(ASCE)0733-9445(2000)126:3(297)

## PUSIAU STANDŽIŲ PLIENINIŲ VARŽTINIŲ MAZGŲ ĮTAKA RĒMINĖS KONSTRUKCIJOS ELGSENAI

A. Daniūnas, K. Urbonas

S a n t r a u k a

Straipsnyje nagrinėjami pusiau standūs mazgai, veikiami lenkiamojo momento ir tempimo ar gniuždymo ašinės jėgos. Daugiausia dėmesio skiriama sijos, sujungtos varžtais per galines plokšteles su kita sija, mazgai. Dažniausiai teigiama, kad ašinės jėgos įtaka mazgo elgsenai yra nereikšminga. Iš tikrųjų gniuždymo ar tempimo ašinės jėgos dydis gali būti reikšmingas ir daryti svarią įtaką mazgo elgsenai, sukamojo standžio ir lenkiamosios galios reikšmėms. Populiariausias ir plačiausiai šiuo metu taikomas metodas mazgo charakteristikoms nustatyti yra komponentų metodas. Šiame straipsnyje rodoma, kaip taikomas komponentų metodas nustatyti mazgo, veikiamo lenkiamojo momento ir ašinės jėgos, charakteristikoms. Pateikiami ir plieninių rėminių konstrukcijų skaičiavimų rezultatai (Daniūnas, Urbonas 2008).

**Reikšminiai žodžiai:** plieninės konstrukcijos, pusiau standūs mazgai, momento ir pasisukimo kreivė, sukamasis standis, lenkiamoji galia, rėmo elgsena.

**Alfonsas DANIŪNAS.** Dr, Assoc. Professor of Steel and Timber Department. Vilnius Gediminas technical university. Lithuania. Research interests: analysis and optimization of elastic and plastic metal structures, semi-rigid connections of steel structures, numerical methods

**Kęstutis URBONAS.** Dr, Assoc. Professor of Steel and Timber Department. Vilnius Gediminas Technical University. Lithuania. Research interests: semi-rigid joints, strength and stiffness of steel semi-rigid joints.